

## 5G Series Connectors



High voltage cylindrical connectors of the new 5G series have been specifically developed to meet the requirements of the "ATLAS" experimental nuclear research programme at the CERN.

The 5G series contains 50 miniature HV 12kV d.c. (test voltage) contacts. These crimp contacts are removable from the shell and are inserted in a PEEK insulator. The same HV contacts are used in the 05 series.

The actual mating is provided by the LEMO Push-Pull system, renowned for its reliability worldwide and a red safety nut to secure the connection.

Two keying alternative (code R or W) are available.

The compact design of these connectors makes them ideal for applications where minimal mass and space saving are critical factors.

### Interconnections

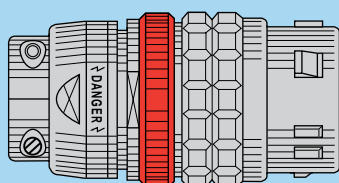

FG<sub>1</sub> Straight plug

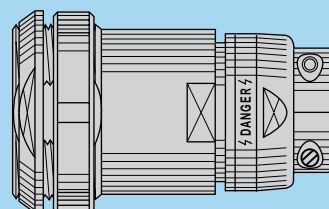

PH<sub>1</sub> Fixed socket

### LEMO's Push-Pull Self-Latching Connecting System

This self-latching system is renowned worldwide for its easy and quick mating and unmating features. It provides absolute security against vibration, shock or pull on the cable, and facilitates operation in a very limited space.

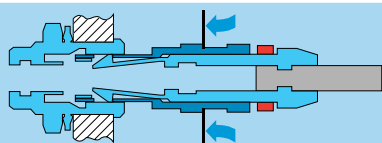
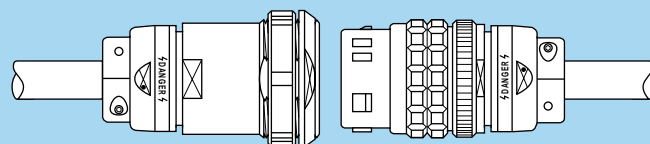
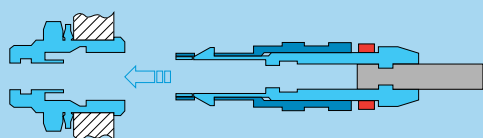

The LEMO self-latching system allows the connector to be mated by simply pushing the plug axially into the socket.

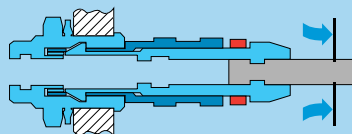

Once firmly latched, connection cannot be broken by pulling on the cable or any other component part other than the outer release sleeve.

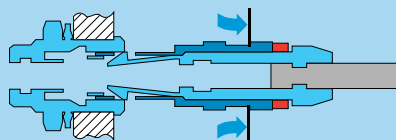

When required, the connector is disengaged by a single axial pull on the outer release sleeve. This first disengages the latches and then withdraws the plug from the socket.

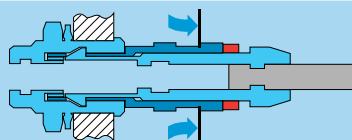

For added security a safety nut (shown in red) can prevent disengagement by blocking the motion of the outer release sleeve.

## Part Section Showing Internal Components

### Connector

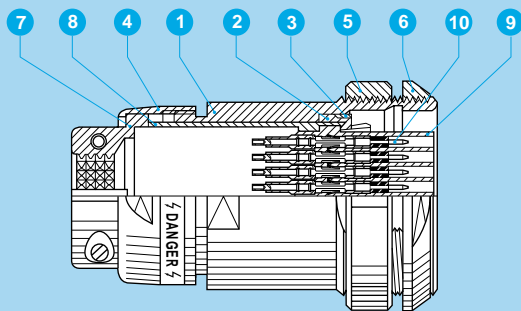

#### Fixed socket

- 1 outer shell
- 2 earthing crown
- 3 retaining ring
- 4 clamp collet nut
- 5 round nut
- 6 conical nut
- 7 adapter w. cable collet
- 8 keyed mid-piece
- 9 insulator
- 10 HV male contact

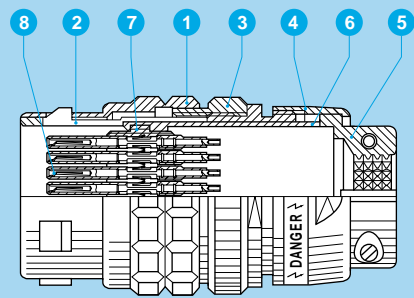

#### Straight plug

- 1 outer shell
- 2 latch sleeve
- 3 safety nut
- 4 clamp collet nut
- 5 adapter w. cable collet
- 6 keyed mid-piece
- 7 insulator
- 8 HV female contact

### HV Contact

#### Male contact

- 1 male contact
- 2 insulator
- 3 clips
- 4 sealing gland

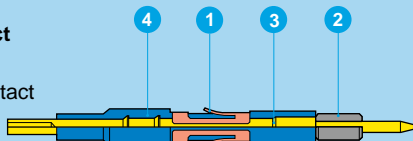

#### Female contact

- 1 female contact
- 2 insulator
- 3 clips

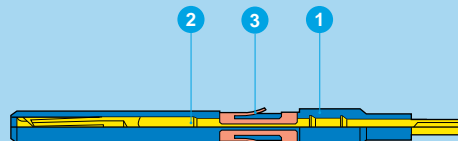

## Technical characteristics

### Mechanical and climatical

Characteristic	Value	Standard
Contact retention force	40 N	IEC 60512-8 test 15a
Working temperature	-20 °C to +125°C	
Mechanical life	> 100 cycles	IEC 60512-5 test 9a
Climatic class	20/125/21	IEC 60068-1
Radiation resistance	>10 <sup>6</sup> Gy	

### Electrical characteristics

Characteristic	Value	Standard
Test voltage d.c. <sup>1)</sup>	12 kV (1 min.)	IEC 60512-2 test 4a
Rated current	4 A	IEC 60512-3 test 5a
Contact resistance	≤ 8 mΩ	IEC 60512-2 test 2a
Screen resistance	≤ 150 mΩ	IEC 60512-2 test 2f
Insulation resistance	≥ 10 <sup>12</sup> Ω	IEC 60512-2 test 3a

**Note:** <sup>1)</sup> specific assembly instructions shall be respected.

### Materials and Treatment – Connector

Component	Material (standard)	Surface treatment (µm)
		Ni
Outershell + collet nut	Aluminium (AA 6012)	Anodized natural
Safety nut	Aluminium (AA 6012)	Anodized red
Earthing crown	Aluminium special	5
Latch sleeve	Aluminium special	5
Round and conical nut	Aluminium (AA 6012)	Anodized natural
Insulator	PEEK	–
Other metallic pieces	Aluminium	Anodized natural

### Contact

Component	Material (standard)	Surface treatment (µm)		
		Cu	Ni	Au
Male contact	Brass (UNS C38500)	0.5	3	1.0
Female contact	Bronze (UNS C54400)	0.5	3	1.5
Contact clips	Cu-Be (QQ-C-530)	–		
Insulator	PEEK	–		
Sealing gland	Silicone PVMQ	–		

## Alignment key and polarized keying system

<p>Front view of a socket</p>	Ref.	Dot Colour	Angle				HV contact type	
			$\alpha$	$\beta$	$\gamma$	$\delta$	Plug	Socket
	●●R	yellow	110°	105°	25°	35°	male	female
●●W	red	95°	115°	20°	30°	female	male	

## Models

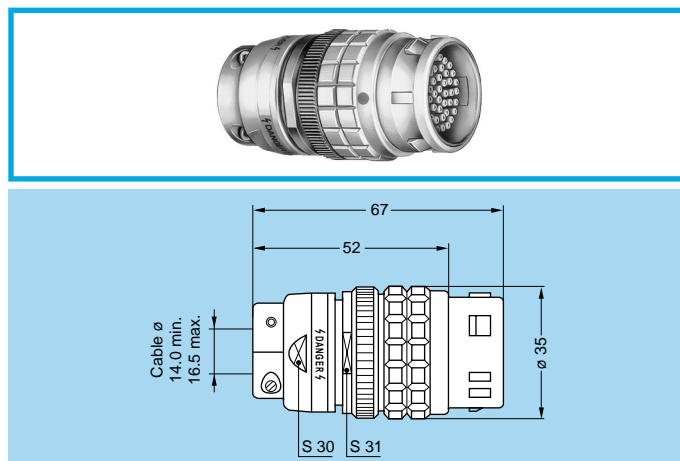

**FG** Straight plug with keys (code R or W), cable clamp-collet and safety nut

Part Number	Cable Group
FGR.5G.450.LLAY5T1	1
FGR.5G.450.LLAY5T2	2
FGW.5G.450.LLLY5T1	1
FGW.5G.450.LLLY5T2	2

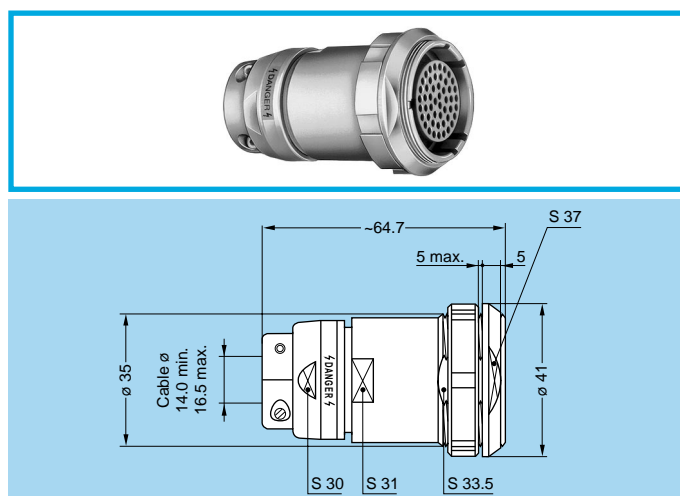

**PH** Fixed socket with keys (code R or W), cable clamp-collet, 2 nuts fixing (back panel mounting)

Part Number	Cable Group
PHR.5G.450.LLLY5T1	1
PHR.5G.450.LLLY5T2	2
PHW.5G.450.LLAY5T1	1
PHW.5G.450.LLAY5T2	2

## Recommended high voltage cables

Cable group	Manufacturer Part Number	CERN Type	Type/Nb. of conductor	Construction and dimensions								
				Conductor			Dielectric		Screen	Sheath		Corona screen
				Constr.	Mat.	$\phi$	Mat.	$\phi$	Mat.	Mat.	$\phi$	
1	SILISOL CEPMB - 56x0.12 mm <sup>2</sup>		Multi/56	7x0.15	CuSn	0.45	PE	1.5	CuSn + Alu	Silic	14.5	no
1	ABBNK - 45/94	HTC 50-1-1	Mono/1	7x0.17	CuSn	0.51	PE solid	1.5	CuSn 16x4x0.1	Polyolefine	3.3	yes
2	HABIA 31789-004-001	HFI 150 mini coax	Mono/1	Mono	Cu	0.16	HFI150	0.5	Drain 2x0.1 + Alu polyester	HFI150	1.15	no

## Accessories

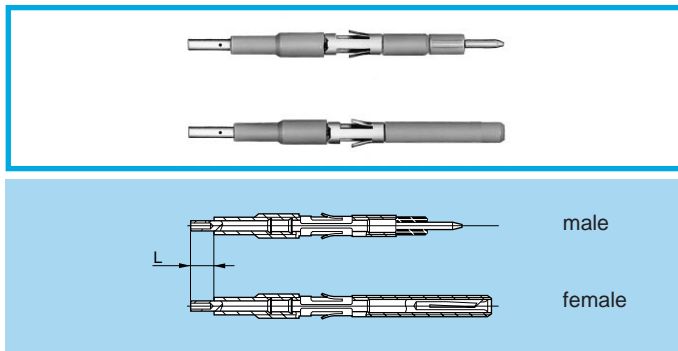

### FFA-ERA HV Contacts

Contact Part Number		Cable group	L (mm)
Male contact	Female contact		
FFA.05.403.ZLA1	ERA.05.403.ZLL1	1	4
FFA.05.403.ZLA2	ERA.05.403.ZLL2	2	6

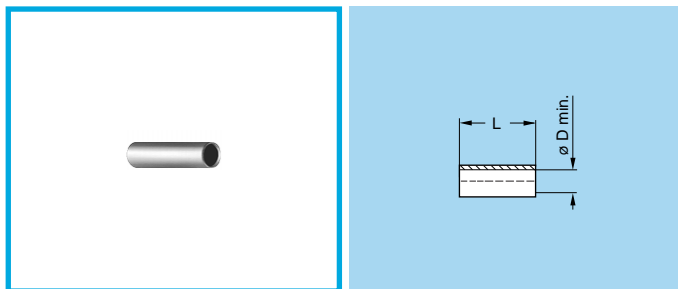

### GMA Heatshrink tube

Shall be ordered separately

Part number	Cable group	Supplier		øD (mm)	L (mm)
		Name	Product reference		
GMA.30.010.ST	1+2	RAYCHEM®	RNF 3000 3/1	3.0	13
GMA.15.010.ST	2	RAYCHEM®	RNF 3000 1.5/0.5	1.5	9

**Note:** for cable group 2, the two heatshrink tubes are necessary

- Material: Polyolefin transparent

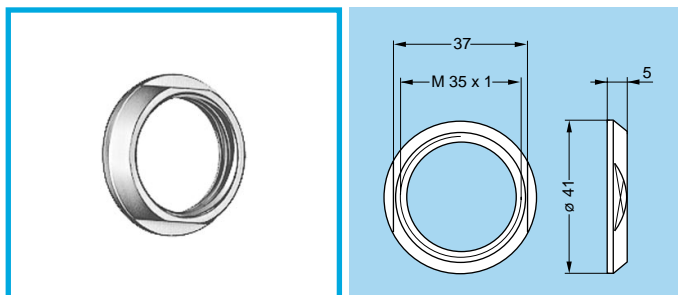

### GEC Conical nut

Part number
GEC.5G.240.PT

- Material: Aluminium alloy (AA6012) natural anodized

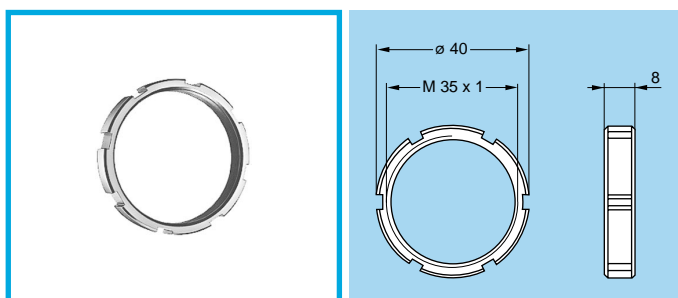

### GEB Round nut

Part number
GEB.5G.240.PT

- Material: Aluminium alloy (AA6012) natural anodized

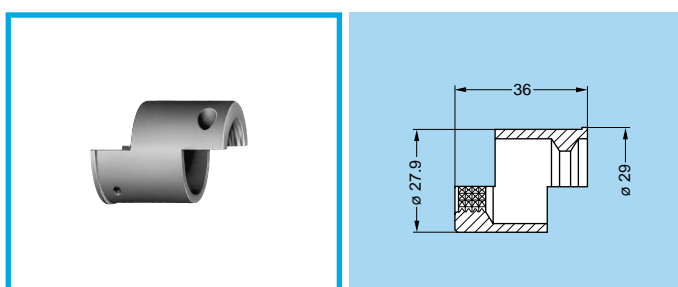

### FGG Extension piece

Part Number
FGG.5G.815.PN

**Note:** allows an extension of the plug or the socket to make cable stripping and mounting easier when weight and size are not critical

- Material: Aluminium alloy (AA6012) natural anodized

## Tooling

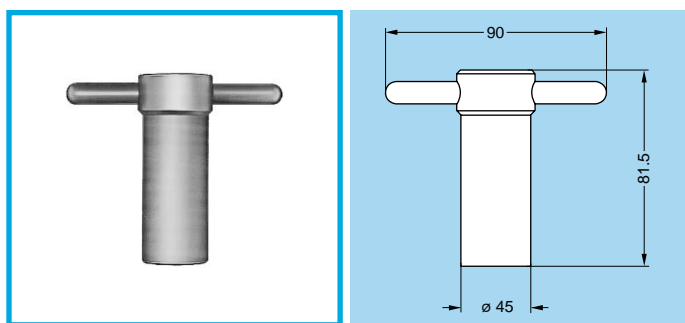

### DCH Spanner for conical nut

Part Number

DCH.91.418.0TN

- Material: Blackened steel.

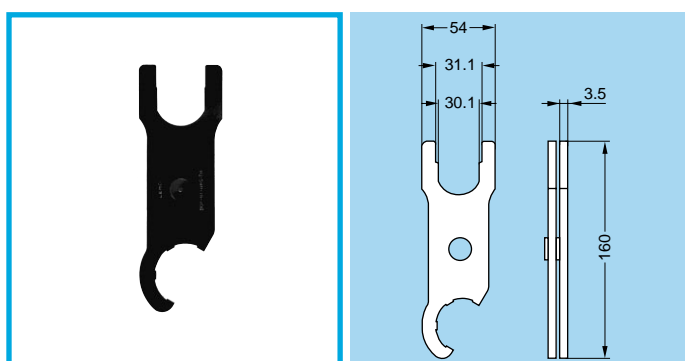

### DCP Set of flat spanners for collet nuts and round nuts

Part Number

DCP.91.005.TN

- Material: Blackened steel.

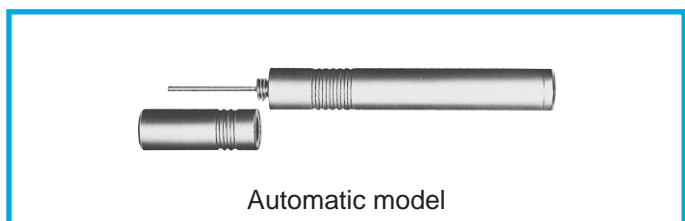

### DCF Extraction tools for HV contacts

Part Number

DCF.91.133.5LT



### DPH Crimping tool with die and positioner

Part Number	Applications	Cable group	Marking on die
DPH.99.005.2K	shield	1-2	DPH.91.005.2K
DPH.99.060.11K	centre contact	1	DPH.91.001.16K
DPH.99.065.11K	centre contact	2	DPK.91.001.16K

**Note:** DPN Dies and positioner: See 05 series data sheet.

## Panel cut-out

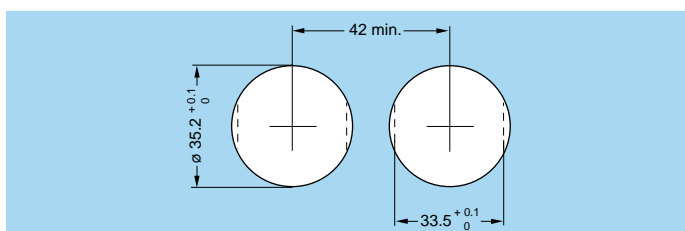

**Recommended mounting nut torque: 7 Nm.**

## Termination Instructions Cable Group 1 (multi HT cable)

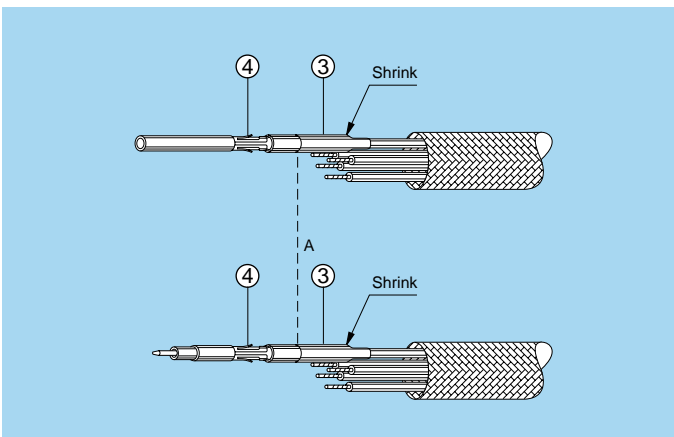
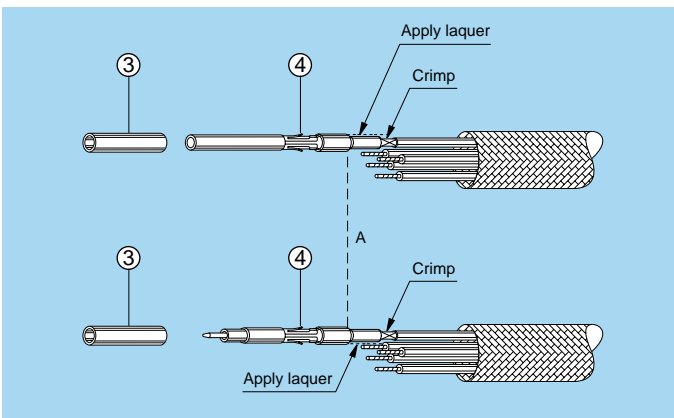
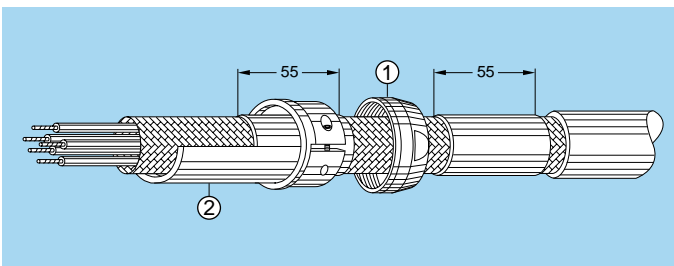
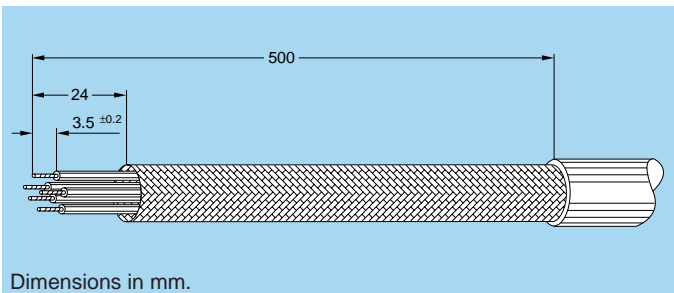
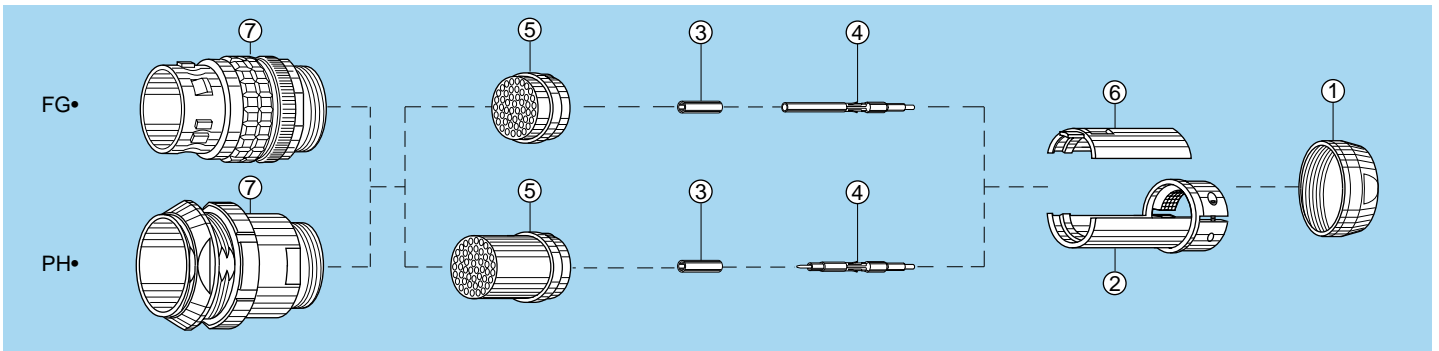

1. Strip the cable according to the given dimensions. A 500 mm length is necessary to give enough flexibility to the cable. Remove first the outer jacket and the screen then the dielectric of each individual high-voltage conductor, making sure that the cable dielectric is not damaged.

2. Slide 2 pieces of 55mm heat-shrink tubing, (not supplied) of the correct size, the clamp collet nut ① and the adapter with cable collet ② on the cable.

3. For each individual high-voltage conductor install a HV contact as follow:

3.1 Introduce the cable center conductor into the HV contact ④ until the conductor end rests against the dielectric and the conductor is visible through the contact inspection hole. Crimp with the LEMO crimping tool DPH.99.060.11K. Cover the crimp section of the contact and the Peek end of the HV contact with a layer of insulating laquer. Let the laquer dry, approx. 15 min.

Note: We recommend the laquer Urethan ref: Cellpack n° 912110

3.2 Slide the heatshrink tube ③ over the HV contact until it rests against the contact insulator. One end of the heatshrink tube shall be located at the position A of the HV contact insulator. Shrink the tube.

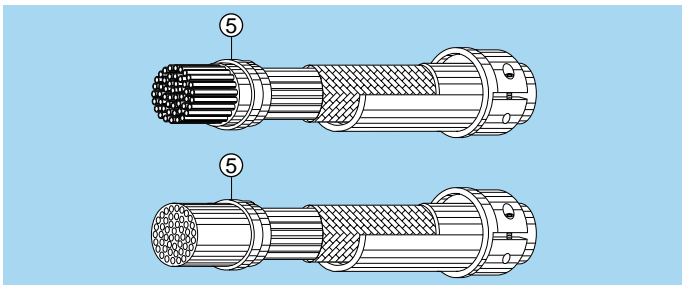

4. Fully introduce the HV contacts into the insulator ⑤.
  - The short insulator shall be fitted with the female HV contacts.
  - The long insulator shall be fitted with the male HV contacts.

Check that the contacts are correctly located and remains in position when given a gentle pull.

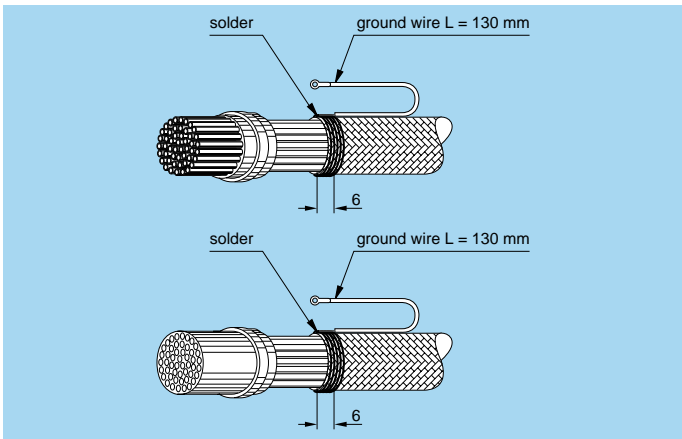

5. Install a ground wire (not supplied) as follow:

- 5.1 Wrap a tin copper wire 0.5 mm<sup>2</sup> over a 6 mm length of the cable screen and hold the ground wire as shown. Then solder.

Solder an earthing washer with a 3.5 mm hole on the other side.

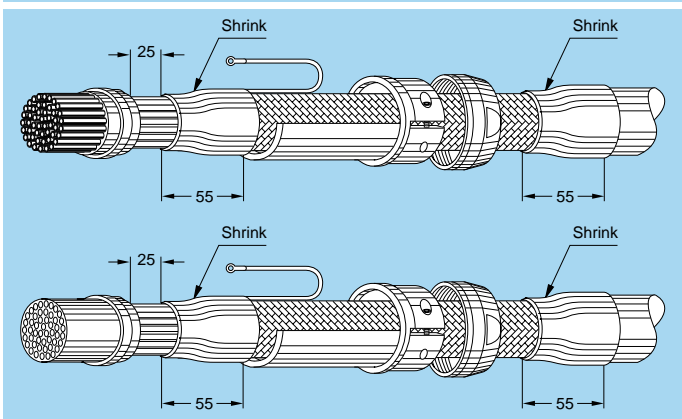

- 5.2 Cover the end of the cable screen with the first heat-shrink tube and the end of the cable jacket with the second heat-shrink tube, then shrink.

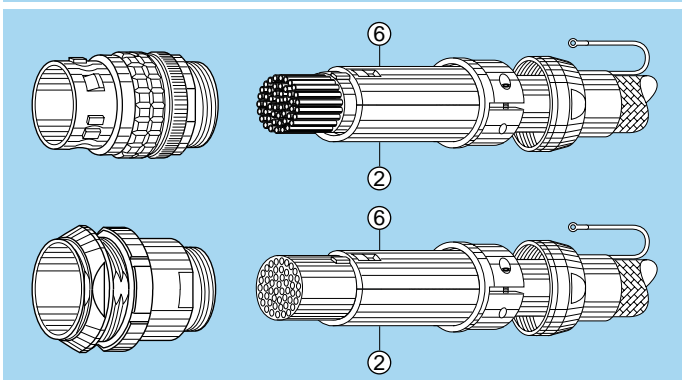

6. Push the adapter with cable collet ② forward over the cable until the insulator locate into the groove on the adapter.

Then fit the keyed mid-piece ⑥ onto the insulator, make sure that the key of the insulator is correctly located into the key of the mid-piece.

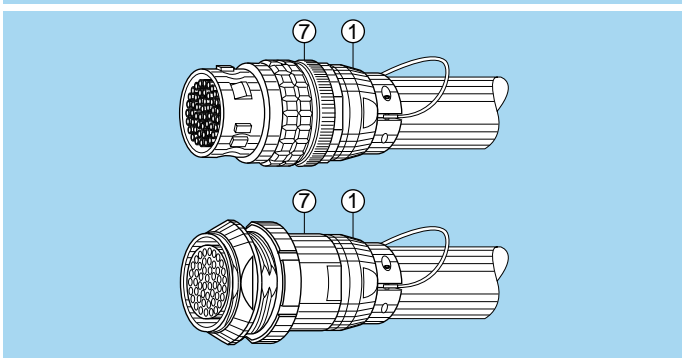

7. Next slide the connector shell ⑦ over the insulator assembly making sure that the key on the keyed mid piece goes into the key-way (under the color point/inside the shell).

– Note that the HV contact type shall be respected depending upon the keying code as indicated on page 10.

Screw the collet nut ① and tighten to the maximum torque value of 4 Nm.

Tight the two screws of the adapter and in between on an appropriate manner the washer of the ground wire.